



OPC COMMUNICATION INTEGRATES PSL-DTS TO SCADA ELIPSE E3

Tiago Torres dos Santos – Lucas Lorensi dos Santos

tiago.santos@powersyslab.com, lucas.lorensi@powersyslab.com
 PowerSysLab Engenharia e Sistemas Ltda

This case presents the experience of PowerSysLab when using Prosys Sentrol to integrate its DTS (Dispatcher Training Simulator) to a SCADA (Supervisory Control and Data Acquisition) platform, through a partnership with the companies Elipse Software, which develops the Elipse E3 and Sul Engenharia which integrates and installs power system control centers.

PowerSysLab Engenharia e Sistemas (PSL) develops and integrates a group of software applications to support the operation of electric power transmission (EMS - Energy Management System) and distribution (DMS - Distribution Management System) systems. One of these applications is the PSL-DTS, a tool which is used to familiarize and to develop experience of the operators under a large variety of normal and emergency operation conditions. When it is integrated into the SCADA system, it allows the operator under training to use the same operation and supervision interface of the system. However, the operator's commands, instead of making real operations, are addressed to a simulator which is able to behave as the real electric system and sends back answers to the supervision interface.

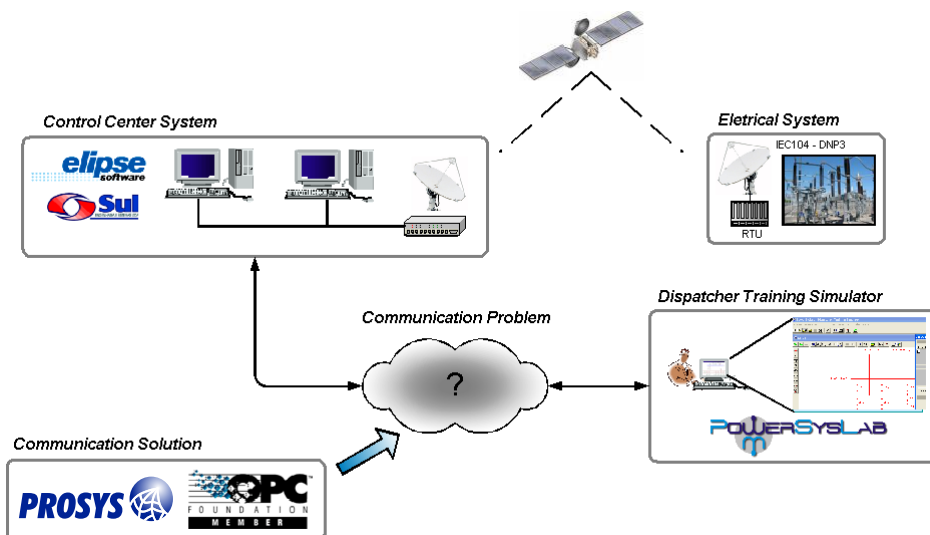

The Elipse E3 allows the communication through OPC (OLE Process Control). To accomplish the integration in an open and standardised way, PowerSysLab decided to develop in the PSL-DTS an OPC Data Access server, in order to carry out the exchange of information between SCADA and PSL-DTS through the reading and writing in OPC variables .

The development of an OPC server is not a simple task and it would demand much time for implementation, tests and validation, become incompatible with the project requirements. It was decided then, that the server should be implemented with the support of a component of the Rapid OPC Application Development Framework type. After consulting OPC Foundation site on the existing products in the market, some versions were tested. The development team ended up selecting Prosys Sentrol because it meets a series of requirements such as:

- OPC Foundation Certified
- Integrated into the Borland® Developer Studio environment
- Allows the development of OPC Server and Clients
- Help integrated into the development environment
- Examples with source code
- Tutorial
- Technical support
- Royalty free
- Price

Figures show screen shots of the software in operation.

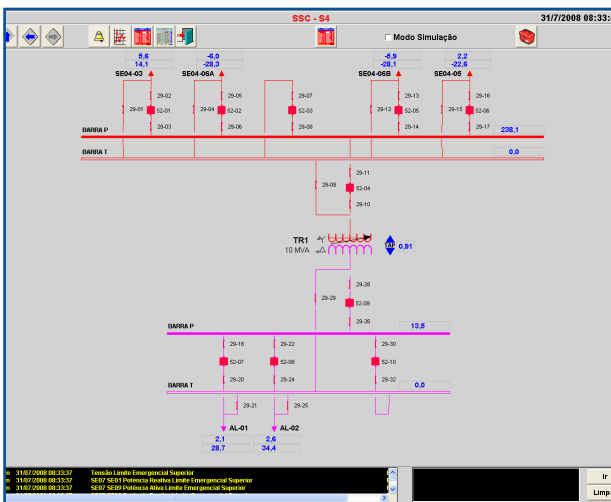

SCADA developed on the Eclipse E3 platform integrated to the simulator

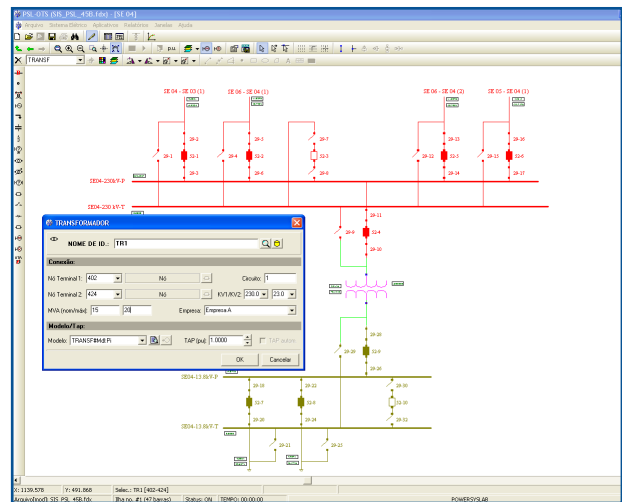

PSL-DTS simulating a case example and supplying data to SCADA through Prosys Sentrol OPC server.

“ The PowerSysLab developers were amazed when, after a day of work integrating the component Prosys Sentrol into PSL-DTS, some variables were already available to be accessed by OPC clients. A week later the component was fully integrated to the simulator and all of the expected functionalities were reached. The final validation of the OPC server was accomplished with the integration of PSL-DTS to the SCADA system developed by Sul Engenharia on the platform Eclipse E3.”

Tiago Torres dos Santos, PowerSysLab

Prosys PMS Ltd
Tekniikantie 14
02150 Espoo, Finland
+358 9 420 9007
sales@prosysopc.com